

SBA4100-GM02 Series
Single Channel Gain Block
MSA Compact EDFA Module

Technical Specification

CONTENT

| | |
|---|----------|
| 1.0 PRODUCT DESCRIPTION..... | 1 |
| 2.0 PRODUCT FEATURE..... | 2 |
| 3.0 MAIN APPLICATION..... | 2 |
| 4.0 FUNCTIONAL DIAGRAM..... | 3 |
| 5.0 DIMENSIONS..... | 3 |
| 6.0 ELECTRICAL 20-PIN ASSIGNMENTS..... | 4 |
| 7.0 TECHNIQUE INDEX..... | 5 |
| 7.1 OPTIC FEATURE & GENERAL FEATURE..... | 5 |
| 7.2 INPUT AND OUTPUT MONITOR PD SPECIFICATIONS..... | 6 |
| 7.3 PUMP LASER SPECIFICATIONS..... | 6 |
| 8.0 PRODUCT SERIES..... | 7 |
| 9.0 ORDER INFORMATION..... | 7 |

1.0 PRODUCT DESCRIPTION

SBA4100-GM02 is a single channel gain block booster EDFA module, adopts 70 × 90 × 12mm MSA compact package. It is featured with high reliability, superior optical performance and compact reasonable configuration by Industrial standard, creating the most flexible and variable low-cost amplifier in the market. This module is suitable for multiple network application, especially the application that requires 40GB/S transmission speed.

SBA4100-GM02 single channel gain block booster EDFA module adopts the standard version of single channel and narrow bandwidth. The module uses high performance pump laser that with cooling function. A standard 20-PIN electric connector (HIROSE DF11-20DP-2DSA) allows the simple electric connection.

SBA4100-GM02 single channel gain block booster EDFA module, main installed behind the optical transmitter to increase the output power of the transmitter and extend the signal transmission distance.

2.0 PRODUCT FEATURE

- Gain Block
- Wide operating temperature range
- Output power 13~23dBm optional
- MSA compact package (70×90×12mm)
- Low power consumption
- Low cost

3.0 MAIN APPLICATION

- Metropolitan and access networks
- CATV
- Single-channel or DWDM sub-systems
- Optical Add/Drop and Cross-Connects
- Transmitter and Receiver Amplification
- Power equalization and flexible pre-emphasis

4.0 Functional diagram

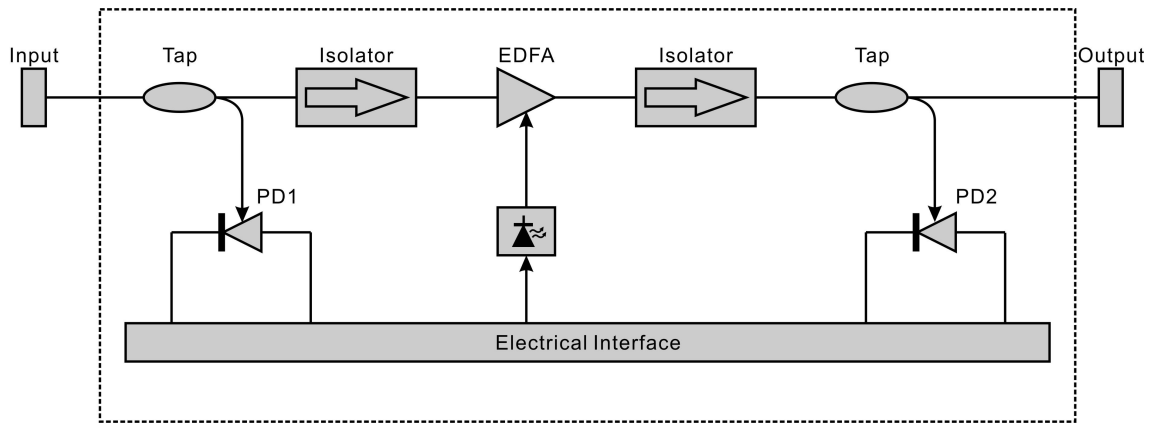

5.0 Dimensions

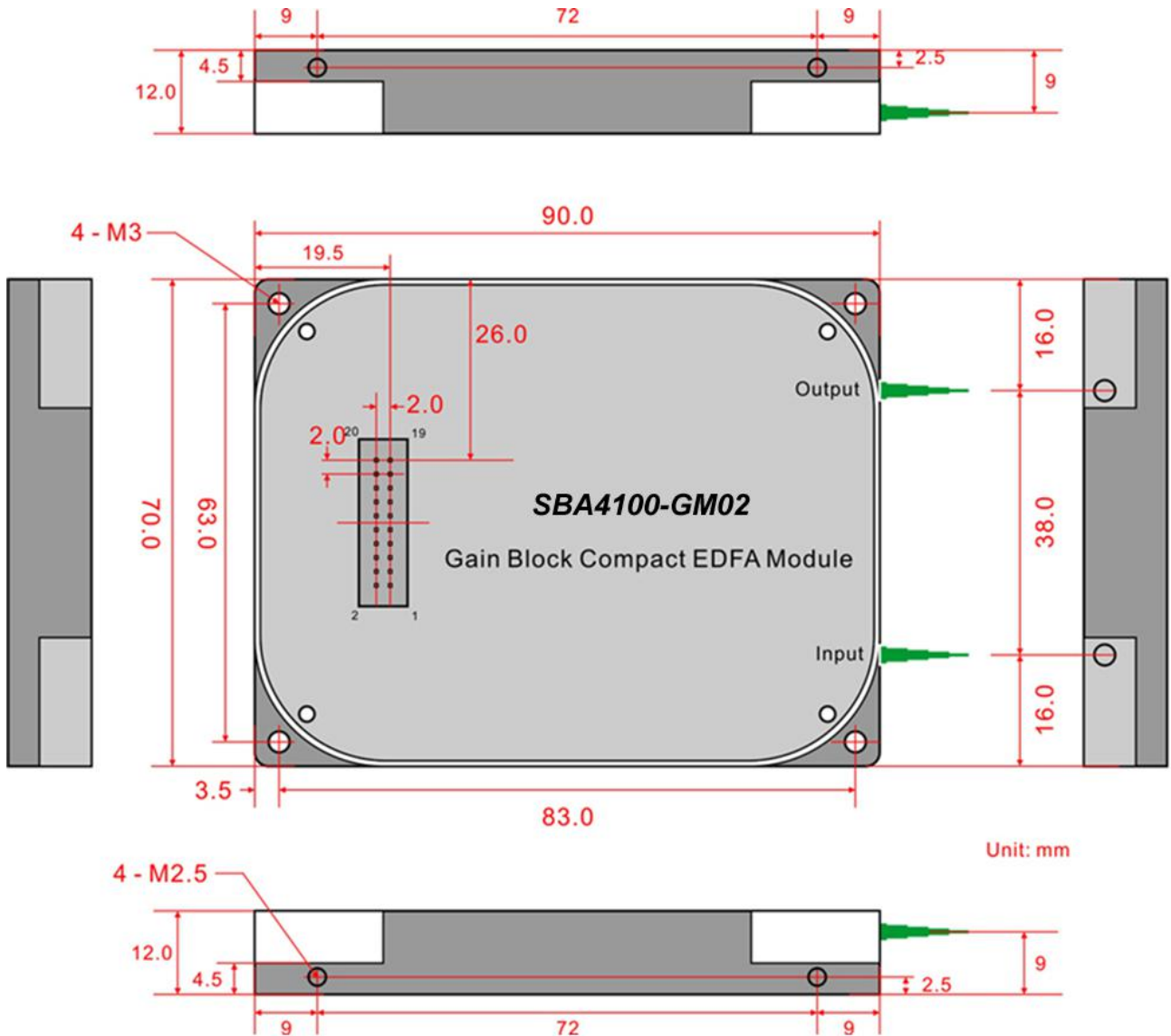

6.0 Electrical 20-Pin Assignments

| Pin | Definition | Pin | Definition |
|-----|---------------------------------------|-----|-------------------------------------|
| 1 | Ground, optical power monitor PD | 2 | Input monitor PD cathode (-) |
| 3 | Input monitor PD anode (+) | 4 | Output monitor PD cathode (-) |
| 5 | Output monitor PD anode (+) | 6 | Thermistor |
| 7 | Pump laser diode anode (+) | 8 | Pump laser diode anode (+) |
| 9 | Pump backfacet monitor PD cathode (-) | 10 | Pump backfacet monitor PD anode (+) |
| 11 | TEC anode (+) | 12 | TEC anode (+) |
| 13 | TEC anode (+) | 14 | TEC cathode (-) |
| 15 | TEC cathode (-) | 16 | TEC cathode (-) |
| 17 | Ground, pump laser diode | 18 | Thermistor |
| 19 | Pump laser diode cathode (-) | 20 | Pump laser diode cathode (-) |

Note 1: Electrical connection is made via a male 20 PIN connector (2 rows of 10, pin pitch 2.0mm, 0.5×0.5mm), Samtec TMMH-110-01-G-DV-EC or equivalent.

Note 2: The gain block case is isolated with the pump laser diode case.

7.0 Technique index

7.1 Optic feature & General feature

| Performance | | | Min. | Typ. | Max. | |
|----------------------------------|------------------------------------|--------------|-------|--------------------------|------|------|
| Optic feature | Operating wavelength range | | (nm) | 1528 | | 1564 |
| | Input optical power (Pin) | | (dBm) | -10 | | +4 |
| | Total Output power @ Pin=0dBm | SBA4113-GM02 | (dBm) | 13 | | |
| | | SBA4114-GM02 | | 14 | | |
| | | SBA4115-GM02 | | 15 | | |
| | | SBA4116-GM02 | | 16 | | |
| | | SBA4117-GM02 | | 17 | | |
| | | SBA4118-GM02 | | 18 | | |
| | | SBA4119-GM02 | | 19 | | |
| | | SBA4120-GM02 | | 20 | | |
| | | SBA4121-GM02 | | 21 | | |
| | | SBA4122-GM02 | | 22 | | |
| | SBA4123-GM02 | 23 | | | | |
| | Noise figure | | (dB) | | 4.0 | 5.0 |
| | Polarization dependent gain (PDG) | | (dB) | | | 0.3 |
| | Polarization mode dispersion (PMD) | | (ps) | | | 0.3 |
| Polarization dependent loss(PDL) | | (dB) | | | 0.3 | |
| Pump power leakage | | (dB) | | | -30 | |
| Output & input isolation | | (dB) | 30 | | | |
| Return loss | UPC | (dB) | 45 | | | |
| | APC | | 55 | | | |
| General feature | Fiber type | | | SMF-28, 900μm loose tube | | |
| | Connector type | | | LC, SC, FC | | |
| | Connector polish | | | UPC, APC | | |
| | Operating temp. | | (°C) | -5 | | 70 |
| | Store temp. | | (°C) | -40 | | +85 |
| | Relative humidity | | (%RH) | +5 | | +95 |

| | | |
|---------------------|------|-------------|
| Size(W) × (L) × (H) | (mm) | 70× 90 × 12 |
|---------------------|------|-------------|

7.2 Input and Output Monitor PD Specifications

| Performance | | Min. | Typ. | Max. |
|--------------------------------|-----------------------------|------|------|------|
| Input monitor PD responsivity | ($\mu\text{A}/\text{mW}$) | 30 | - | 75 |
| Output monitor PD responsivity | ($\mu\text{A}/\text{mW}$) | 1.0 | - | 25 |
| Monitor PD reverse voltage | (V) | - | 5 | 20 |
| Monitor PD forward current | (mA) | - | - | 10 |
| Dark current (-5V, 25°C) | (nA) | - | - | 5 |

7.3 Pump Laser Specifications

| Performance | | Min. | Typ. | Max. |
|---|---------------|------|------|------|
| Pump laser threshold current | (mA) | - | 40 | 55 |
| Pump laser operating current (BOL) | (mA) | - | - | 1200 |
| Pump laser operating voltage | (V) | - | - | 2.6 |
| TEC current (max. $\Delta T=50^\circ\text{C}$) | (A) | - | - | 2.2 |
| TEC voltage (max. $\Delta T=50^\circ\text{C}$) | (V) | - | - | 3.3 |
| Thermistor resistance (25°C) | (K Ω) | 9.5 | 10 | 10.5 |

8.0 PRODUCT SERIES

| Model | Input optical power (dBm) | Output power (dBm) (Pin=0dBm) | Pump laser | Noise figure (dB) |
|----------------|---------------------------|----------------------------------|------------|-------------------|
| SBA4113-GM02-C | -10~+4 | 13 | Cooling | <4.0 |
| SBA4114-GM02-C | -10~+4 | 14 | | <4.0 |
| SBA4115-GM02-C | -10~+4 | 15 | | <4.0 |
| SBA4116-GM02-C | -10~+4 | 16 | | <4.0 |
| SBA4117-GM02-C | -10~+4 | 17 | | <4.0 |
| SBA4118-GM02-C | -10~+4 | 18 | | <4.0 |
| SBA4119-GM02-C | -10~+4 | 19 | | <4.5 |
| SBA4120-GM02-C | -10~+4 | 20 | | <4.5 |
| SBA4121-GM02-C | -10~+4 | 21 | | <4.5 |
| SBA4122-GM02-C | -10~+4 | 22 | | <5.0 |
| SBA4123-GM02-C | -10~+4 | 23 | | <5.0 |

9.0 ORDER INFORMATION

SBA 4 1 □□ - GM 02 / □□ - □□

| Product series | Optical bandwidth | | Product Type | | Output power | | Module Type | | Exterior | | Connector | | Fiber length | |
|-------------------------------------|-------------------|-----------------------|--------------|----|--------------|-------|-------------|-------------------------|----------|--------------|-----------|--------|--------------|------|
| Single-channel BA EDFA Module | 4 | C-Band (1528~1564) | 1 | BA | 13 | 13dBm | GM | Gain block module | 01 | 40 × 70 × 12 | LA | LC/APC | 05 | 0.5m |
| | | | | | 14 | 14dBm | | | 02 | 70 × 90 × 12 | LP | LC/UPC | 08 | 0.8m |
| | | | | | 15 | 15dBm | FM | Full function module | SA | SC/APC | 10 | 1.0m | | |
| | | | | | 16 | 16dBm | | | SP | SC/UPC | | | | |
| | | | | | 17 | 17dBm | | | FA | FC/APC | | | | |
| | | | | | 18 | 18dBm | | | FP | FC/UPC | | | | |
| | | | | | 19 | 19dBm | | | | | | | | |
| | | | | | 20 | 20dBm | | | | | | | | |
| | | | | | 21 | 21dBm | | | | | | | | |
| | | | | | 22 | 22dBm | | | | | | | | |
| | | | | | 23 | 23dBm | | | | | | | | |